

Interactive Calibration for the SSARR Watershed Model

D.M. ROCKWOOD AND D.W. KUEHL
Partners, SAR Consultants
Vancouver, Washington 98664 U.S.A.

ABSTRACT

This paper illustrates an improved, efficient method for calibrating the watershed portion of the Streamflow Synthesis and Reservoir Regulation model (SSARR). This is made possible by the recent advances in the personal computer (PC) version of the model, together with the advances in the new highly developed Personal Computers.

Calibrations are performed interactively within the framework of the SSARR data processing system, operating under an MS-DOS environment. The system provides generalized parameter functions, water balance determinations, statistical error evaluations, and graphical screen displays of results.

INTRODUCTION

The SSARR model has been progressively developed and applied world-wide for more than 35 years to synthesize stream flow and reservoir regulation for a variety of conditions and purposes. The model is a distributed model which simulates runoff by elevation zones. It incorporates a variety of snow accumulation and snow melt algorithms for those drainages where snow melt is an important contributor to runoff.

All the operations illustrated in this paper are accomplished within the capabilities of the current SSARR program, which is available from the North Pacific Division, Corps of Engineers, Portland OR.

Calibration of the watershed model is probably the most important aspect in the creditable use of the model. The model employs numerous variables and functions, which simulate the hydrologic and snow

melt processes. Although there are general definitions of the functions or variables, the specific functional relationships for a particular drainage must be determined by trial and error simulation to obtain the best fit to historical stream flow.

The calibration process is a combination of art and science. The interactive calibration of the model provides for combining the knowledge and experience of the hydrologist and the program capabilities into a highly flexible system for mathematically optimizing the various hydrologic and meteorological elements for synthesizing stream flows.

Historically, calibration of the SSARR watershed model was performed by submitting multi-year batch runs to main frame computers to test the effect of a change in a single parameter or function. The best fit of the simulated versus observed stream flows was obtained, by subjectively adjusting model parameters. This process was necessarily time consuming, and the quality of results depended largely on the experience and judgment of the hydrologist.

Interactive Calibration Technique

Several major improvements and new capabilities related to the calibration of the SSARR watershed model have been developed in recent years. The primary objective of these improvements is to provide a means for processing calibrations objectively and interactively.

In interactive calibration the hydrologist, working at the PC or work station, processes the runs directly with near-immediate response, and judges the results for adequacy using readily available visual and tabular outputs. Adjustments to

parameter values are prepared interactively for the next trial run. Most of the calibration techniques have been presented in the SAR Consultants seminars and workshops.

The major new capabilities and improvements for calibration are summarized as follows:

1. The main frame SSARR program has been ported to MS-DOS PC's and other systems such as RISC work stations which support FORTRAN compilers. These machines can exploit the latest version of the SSARR model and provide the fast response, which is the key to efficient interactive calibration.
2. Version 8 of the SSARR model which provides the "Integrated-Snowband" watershed model was used for this paper. Snowmelt runoff is computed through use of zonally distributed parameters. The algorithms for this model are described in Corps of Engineers (1991). Basic concepts used for computing snowmelt runoff are put forth in Corps of Engineers (1956).
3. Tabulations of volumes for the components of Mean Monthly Water Balance for each year of simulation are computed. The water balance report presents the basin and zonal values of precipitation, snow accumulation, snow melt, interception, evapotranspiration, soil moisture change, generated runoff, infiltration, contribution to surface, sub-surface, base flow, and lower zone components of flow. These quantities stated as mean depth over the drainage are of prime importance in judging the reasonableness of the simulations.
4. Monthly Summaries of flow, volume, and error statistics are processed to help judge the relative adequacy of the assigned parameter coefficients.
5. Instantaneous color screen plots of hydrographs and values of watershed hydrologic parameters, for each year's simulation are available. Also provided are plots of accumulated error statistics.
6. All details of the entire period simulation are stored on MS-DOS files for immediate analysis and monitoring of the continuity of each of the hydrologic variables.
7. By use of specially defined MS-DOS "BAT" files, the program automatically computes multiple simulations in a single run. This capability provides for specifying a range of values or functions of a particular parameter resulting in more rapid convergence of a particular parameter to its optimum value.
8. The calibration system includes a set of generalized table parameter functions. These

functions are contained in a file designated as MET.TBL, for use in simulations employing the metric system. These tables provide a range of functional values which would cover normal experience. These table functions are used in the initial calibration solutions.

9. A schematic of the system for calibration, using all of the above listed capabilities is shown on Figure 1. The interactive processing of the model with a range of parameter values, together with immediate display of results, permits rapid closure to optimum parameter values. The best calibration within the overall capabilities of the model, the data and the experience of the hydrologist is achieved with a minimum of time.

DEMONSTRATION WATERSHED

To demonstrate this calibration technique the Croche River, a small tributary watershed to the St. Maurice River, was selected. It joins the St. Lawrence River 150 kilometers upstream from Quebec City.

The data set was provided by SNC (consultant to Hydro Quebec) with permission of Hydro Quebec. It consisted of two stations with daily temperature and precipitation for a period of six years (Water Years 1969-1974). Runoff consisted of mean daily flow values.

The Croche watershed is long and narrow, running southward 100 kilometers from above the 48° latitude. Watershed elevations range from 170 to 650 meters above mean sea level with a rather flat area elevation curve. The area has second growth tree cover. The runoff response to the observed precipitation suggests that the soil mantle is thin and the watershed has greater than normal areas of rock outcropping and/or water surfaces.

Calibration Approach

The calibration process can consume copious man-hours if not done in a systematic, disciplined manner. In the past watershed calibration process stopped quite frequently based on the time allotted, because no convenient means of testing the sensitivity of parameters was available.

The interactive method discussed above may be thought of as a "five-clone" approach. It allows rapid convergence of the parameter values, and results in efficient time utilization. The ability to confirm the sensitivity and optimum value of each parameter increases the confidence in the completed calibration.

The five-clone approach was applied to the Croche watershed with the system computing all six years with each clone having a variation of a single parameter or function. The number of clones in a run is not limited to five, but five is a practical compromise between flexibility, complexity and computer time.

By sending all output to MS-DOS files the "through time" is significantly reduced. Screen access and hard copy output are available at the option of the operator. Hard copy displays are used only for final documentation. Screen output to monitor the results is available via MS-DOS commands, however frequently used displays can be automated in the BAT routine. During the processing the screen displays only the MS-DOS prompts.

Reports written to file include:

- (1) complete listing of computations for each zone and total watershed(Z+W),
- (2) water balance report(Z+W),
- (3) statistical summary(W),
- (4) hydrograph data,
- (5) mass deviation data, and
- (6) any requested columnar listing.

Automated screen and printer output are available at the option of the operator, but it is most efficient to have tabular listings and plots available upon request.

This calibration was performed on a MS-DOS PC with a 486-33 chip, and a fast, well cached, 210 meg hard disc. The elapsed time for one run of five clone watersheds was a minute per year. After analysis of the completed run the time to adjust the watershed characteristics is less than two minutes. The hydrologist may re-run the entire period or opt for a number of re-runs of a single year.

Analysis Tools

Prior to active calibration runs it is necessary to check the input data for errors and omissions. Plots of basic hydrologic data, Figure 2, are very useful in purging the hydrologic data of errors, omissions or suspicious data. Analysis of precipitation and runoff records via double mass plots is also highly recommended.

Visual analysis of the screen plot is efficient and effective during nearly all stages of calibration. The reader of this paper must visualize the accompanying figures as presented in color on the monitor screen; they are quite easily read and very workable.

The mass deviation curve replaces the traditional hydrographs of observed versus simulated runoff except when refining short term timing.

The deviation curve condenses a large quantity of intelligence into a single line and is very effective in the water balance and seasonal bias phases of calibration. To illustrate the usefulness of the deviation curve it is super-imposed on the traditional observed versus simulated hydrograph, Figure 3. The units are: the left axis, cubic meters per second for the hydro-graphs and the right axis, centimeters over the water-shed for the deviation curve. Simulation for one year for one clone watershed is presented.

For any period with perfect simulation the deviation curve is a horizontal, straight line. For an imperfect simulation the curve departs from a straight line, rising or falling to represent over or under computation, respectively. A formation of a "V" shape indicates a good volume simulation but with a timing problem.

The simulated flow at the peak on Figure 3 is high therefore the deviation curve rises during this period. At the end of the year the curve approaches zero, indicating that the water accounting equation for this year is balanced.

The deviation curve is ideal for comparing the results of all five clones on a single graph. Figure 4 shows the 1973 simulation for the five clones with varying weights on one precipitation station(P360) while the second is held constant. It is evident that the optimum weight to balance the water year is between 79 and 84 percent.

The proper precipitation station weighting to achieve a water balance for the model can not be determined on the basis of one year. Therefore the deviation curve for the entire run is shown on a single plot, Figure 5. If the model is run with station P360 alone water balance for the available period of record would be achieved with a weight of approximately 108 per cent.

Figure 6 is a similar plot with only precipitation station P560. Weighting of 98.5 per cent would achieve satisfactory water balance. After including both precipitation stations in the model and further adjusting the weights to optimize the fit the resulting deviation curve is shown on Figure 7.

The five-clone plot, Figure 8, presents the observed versus simulated hydrographs for one year. On the monitor screen, in color, this plot is very useful in refining the short term timing parameters. For this plot the surface timing function is varied.

To search for causes of deviations hydrograph plots such as Figure 9 are available. At operator's option any of 36 input variables, internal state variables and coefficients can be plotted on single plots or in multiple plots as shown in Figure 9. This plot appears very cluttered in black and white, but is

quite useful when studied on a colored screen or printer plot.

The selection of parameters to plot is the option of the hydrologist and plots can be for the whole watershed or for any zone and for any time span. Usually winter, snow melt season and late summer/fall periods are plotted separately so as to expand the time scale and increase the definition.

In the final stages of a calibration the decision between closely matched calibrations must be made by use of the statistical summary data. This capability was discussed earlier. Sum of the squared deviations or sum of absolute deviations are the normally used criteria.

CALIBRATION PROCESS

Typical watershed calibration starts with characteristics from an adjacent watershed or functions selected from the MET.TBL, the collection of generalized tables discussed earlier. The initial characteristics are modified on the basis of research and study of watershed's known data such as: drainage area, area elevation, and climatology of precipitation, snow and evaporation.

There are six general steps in the calibration process:

- (1) Assign initial parameter values,
- (2) Purge basic hydrologic data,
- (3) Normalize simulated ET,
- (4) Normalize precipitation station weights,
- (5) Minimize the seasonal bias, and
- (6) Refine the short term timing.

An abnormal quantity of simulated ET would bias the other factors in the model water accounting. Therefore the parameters which compute ET must be adjusted prior to weighting of precipitation to balance the water accounting equation. The simulated normal annual ET must compare favorably with the established normals from climatological studies or evaporation pan measurements. The ET function and weighting is optimized via the five clone runs and checked on the water balance report.

Precipitation station weights are normalized by running the five-clone model with one station at a time with a range of assumed weights and checking the results via the total deviation curve. The optimum weight can usually be determined by the second run for each station.

In subsequent runs both stations will be assigned the normalized weights and result will generally be quite satisfactory for the next phases of the calibration. However, later a sensitivity run should adjust for the precipitation weights to account for the

relative skill of the precipitation stations in simulating the true moisture input.

When attempting to reduce seasonal bias the parameters and functions tested are: soil moisture relation, snow/rain coefficients, snow melt functions and lower zone volume and timing. These are the principle factors which can effect simulated runoff volume seasonally. The individual yearly deviation plot is the best tool for this purpose

To refine the short term timing, the important factors are: base flow volume, surface/sub-surface separation and the flow component routing coefficients. To analyze the progress of the refinement of these factors the use of the five clone observed/simulated plots, Figure 8, where five values of surface flow timing are compared on one plot.

If the above six-step process is followed systematically a moderately acceptable calibration will result. However, for optimum results a second set of sensitivity tests of all parameters and a repeat of step five and six will provide additional refinement and further reduction in the total accumulated deviations.

SUMMARY

Performing watershed calibration interactively on a personal computer is by far the most efficient approach compared to batch runs on a main frame computer.

Five-clone calibration runs speed the calibration process and remove much of the tedium of the turn-around process.

Assigning all the computations and reports to files and accessing only the relevant plot or report reduces computer through time and increases the effectiveness of the hydrologist.

Presentation of plots of all five-clone watersheds simultaneously speeds analysis and provides the needed sensitivity confirmation.

The statistical summary provides objective numerical interpretation and comparison of the calibration runs.

References:

- U.S. Corps of Engineers, NPD, Snow Hydrology, Summary Report of the Snow Investigations, 1956.
- U.S. Corps of Engineers, NPD, Users Manual, SSARR Model, Streamflow Synthesis and Reservoir Regulation, 1991, with addenda.

SSARR INTERACTIVE CALIBRATION TECHNIQUE

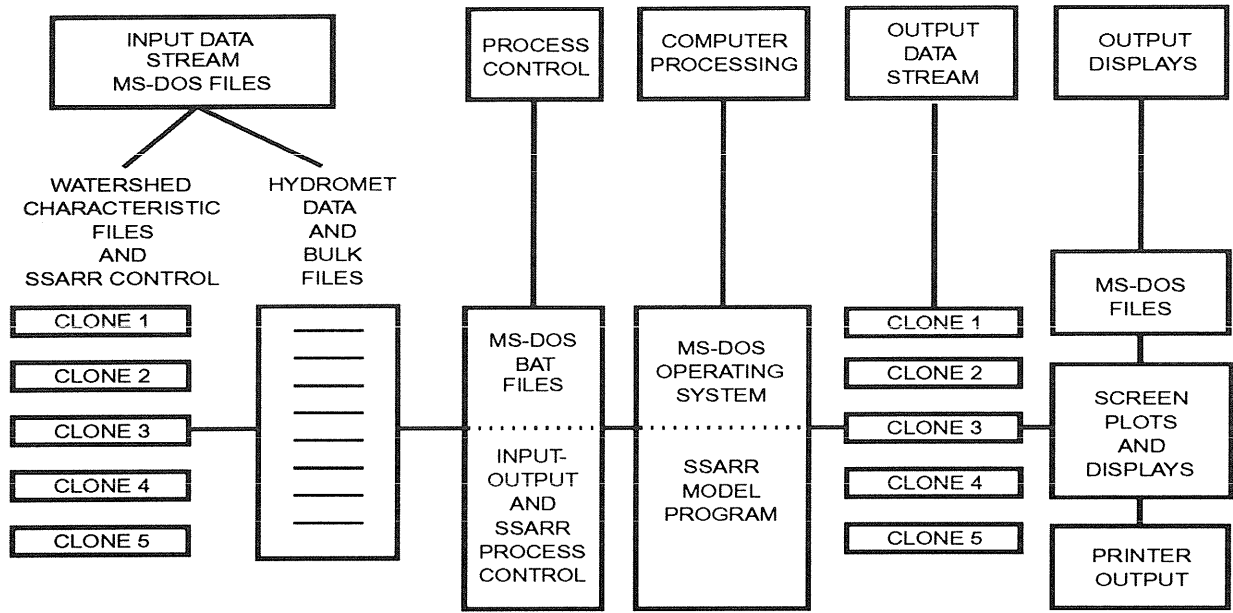

DATA PROCESSING SCHEMATIC

Figure 1

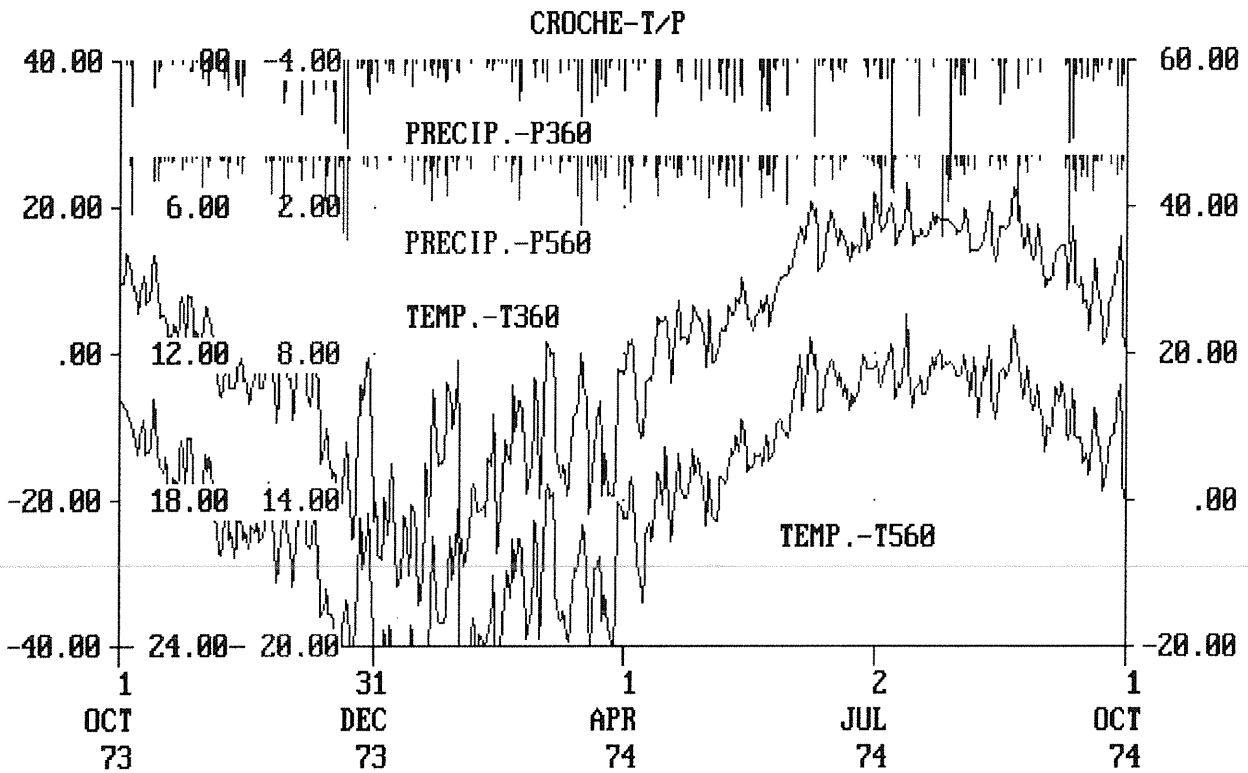

Figure 2

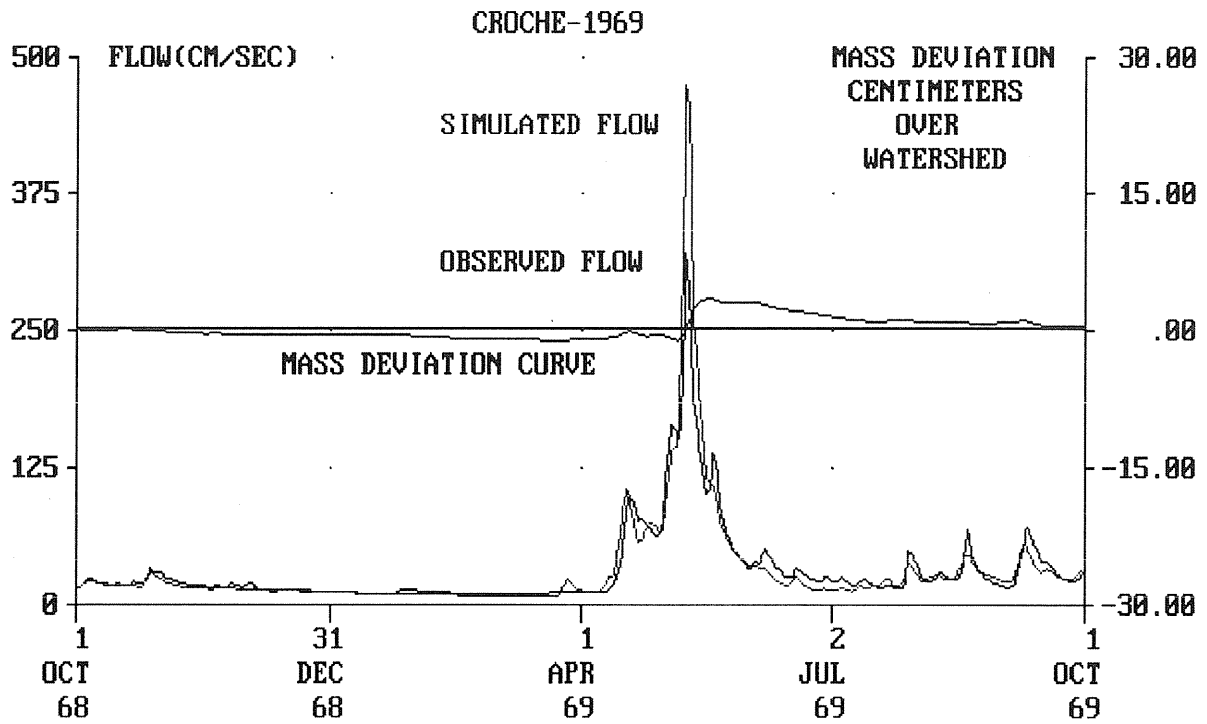

Figure 3

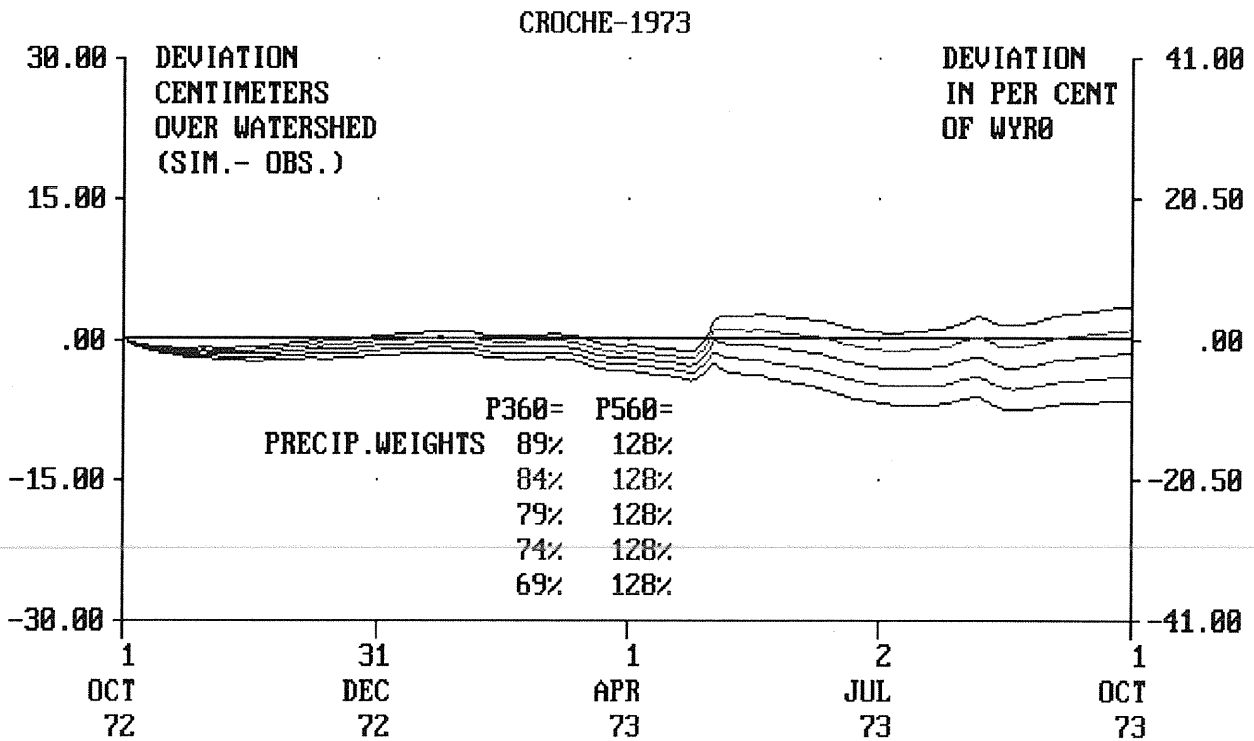

Figure 4

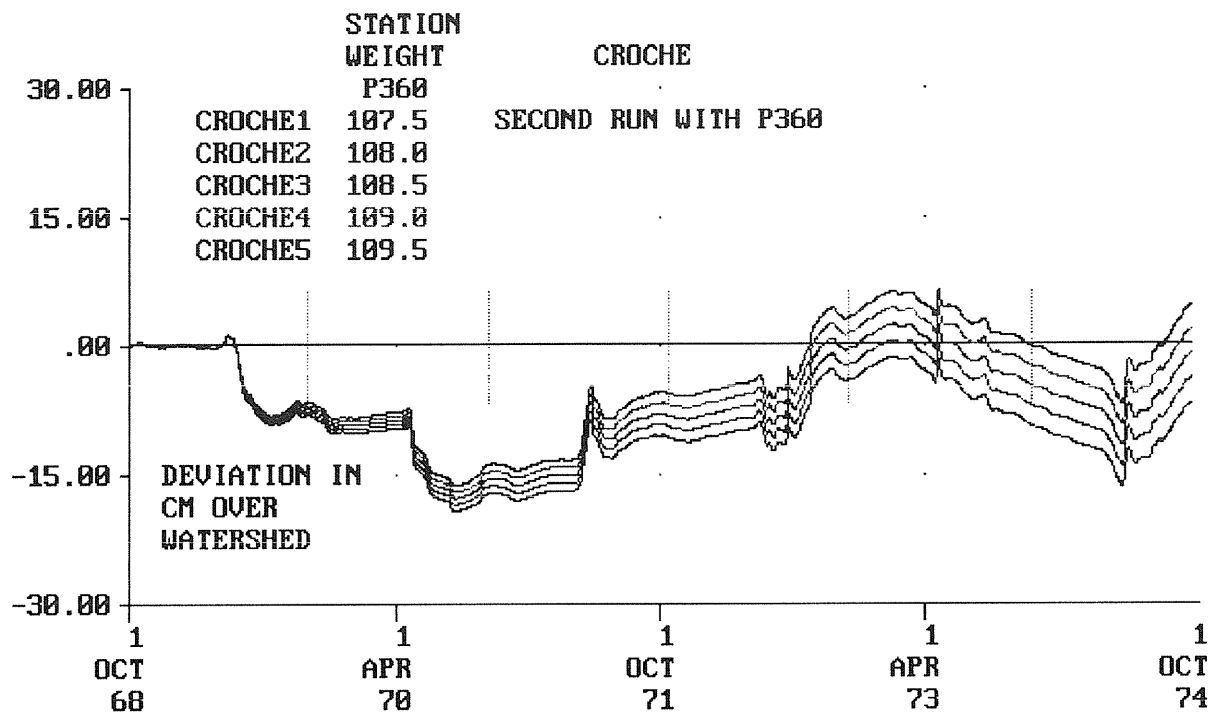

Figure 5

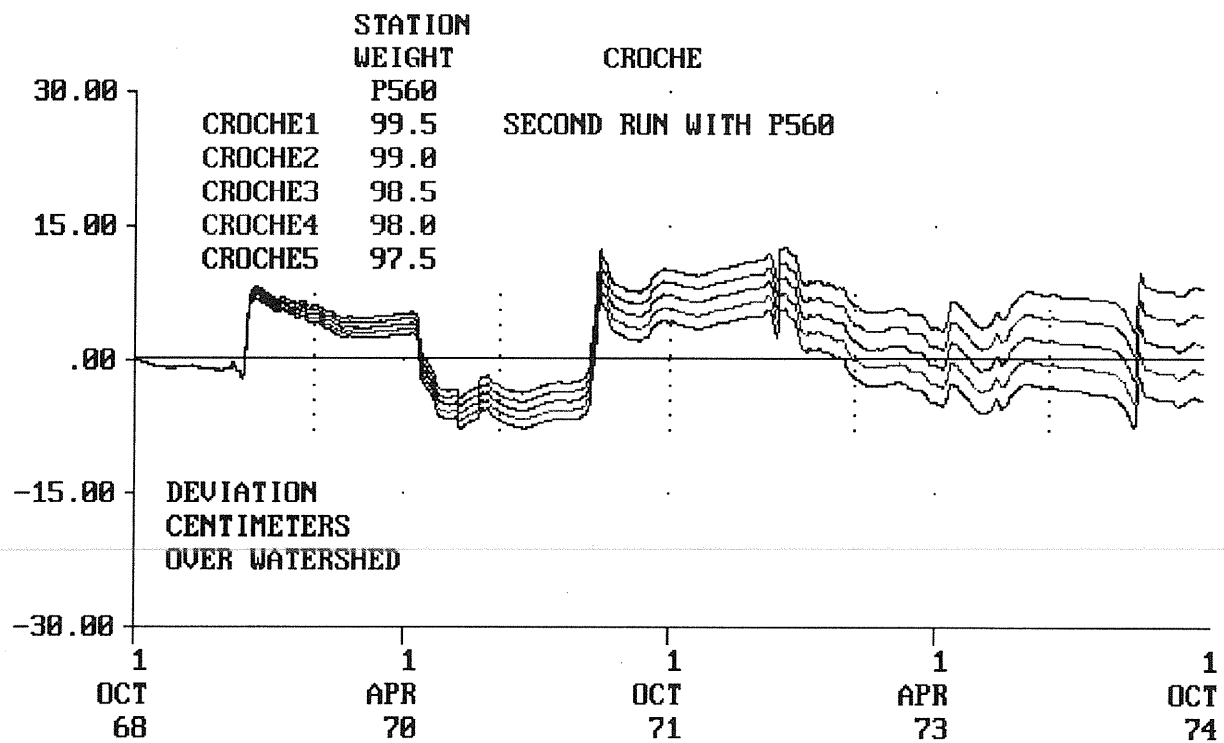

Figure 6

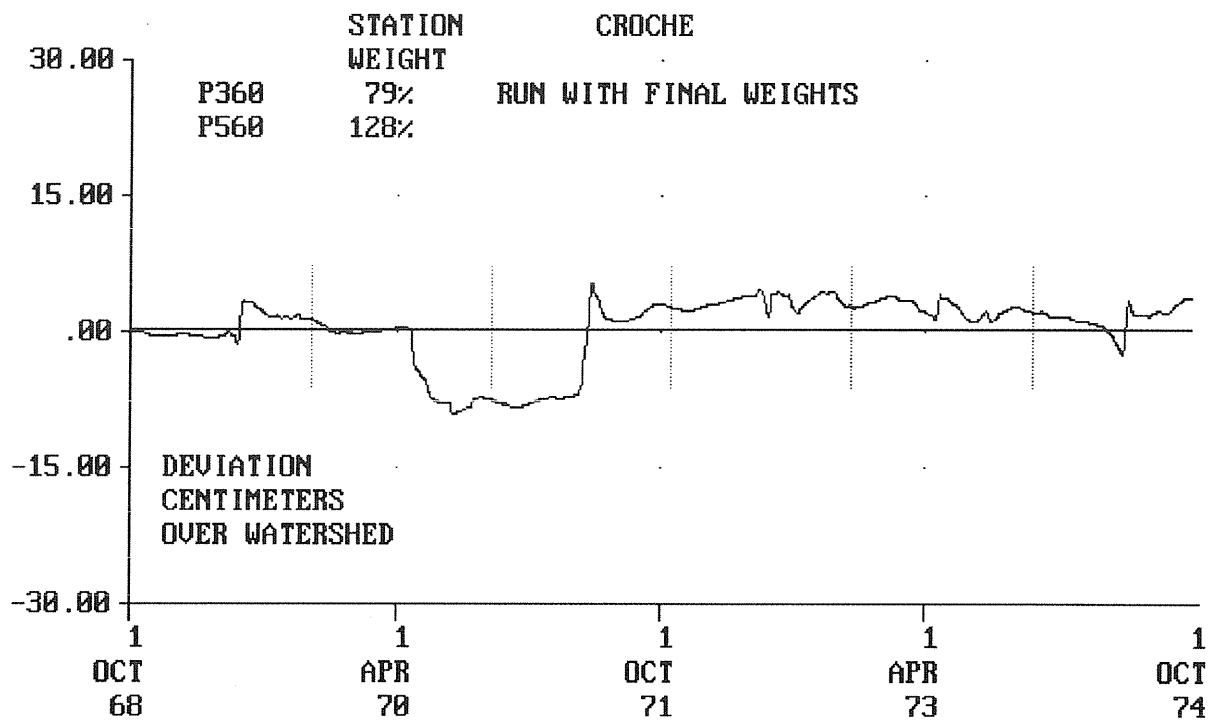

Figure 7

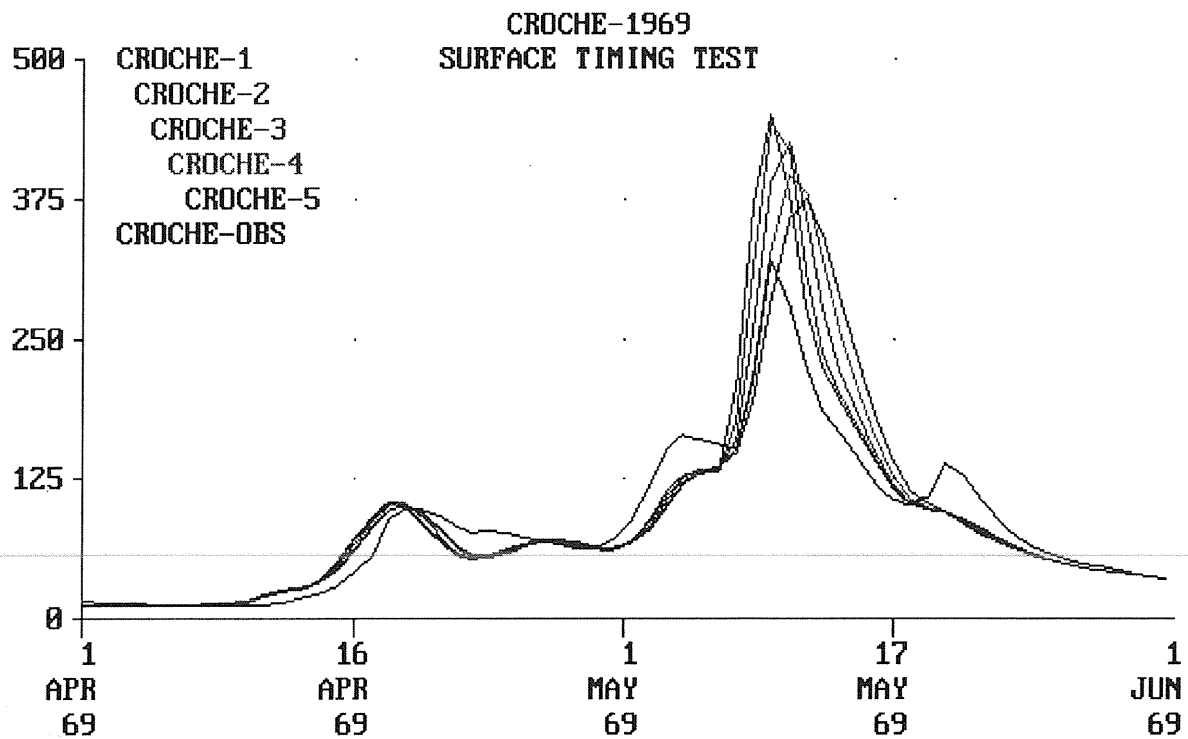

Figure 8

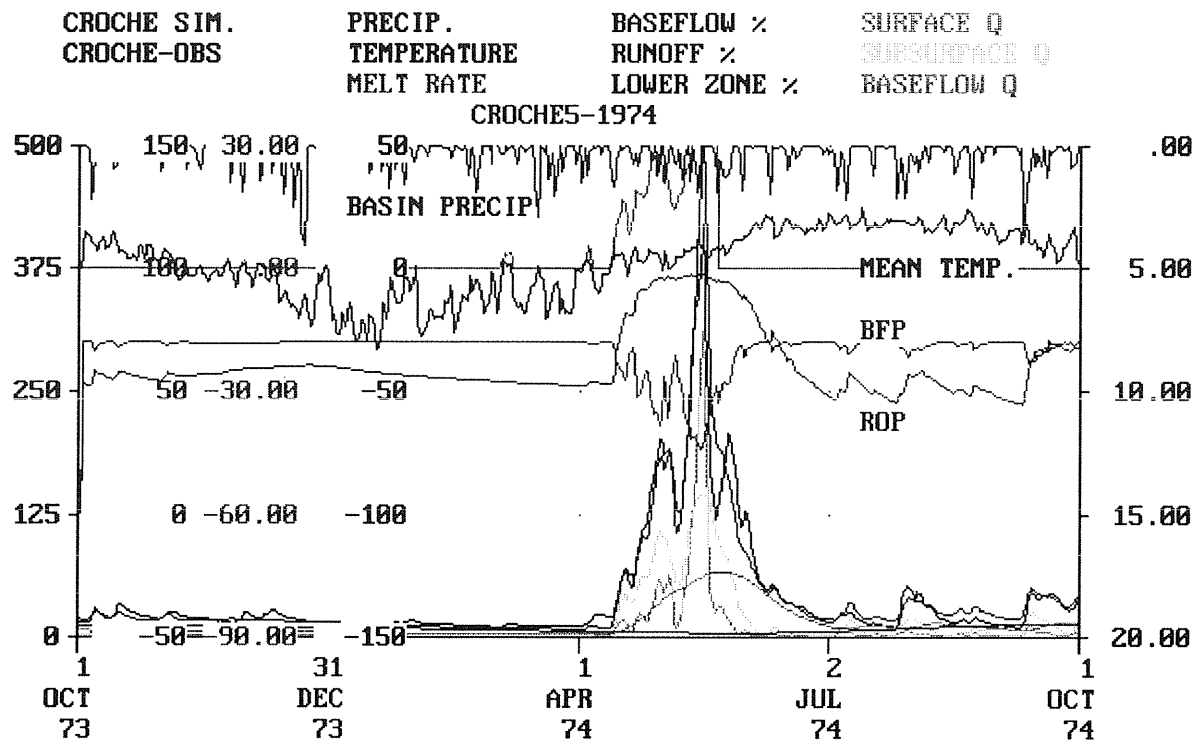

Figure 9

