

## AN ULTRASOUND LOW POWER SONAR FOR SNOW THICKNESS MEASUREMENTS

by Alain Caillet \*, François Gros D'Aillon and Isztar Zawadzki

Département de Physique, Université du Québec à Montréal, Montréal, Québec.

### ABSTRACT

A feasibility study for a low power sonar for automatic measurement of the thickness of the snow layer, using standard electronic components has been carried on. Two prototypes have been built, one for laboratory measurements and one for outdoor installation. Results obtained with the field prototype show that the method is feasible and would be interesting in terms of cost and electric power consumption.

### INTRODUCTION

Numerous ways and systems are and have been used to measure the thickness of the snow layer from simple poles and rulers to sophisticated gamma ray systems, from hand drilling to complex mechanical systems.

Without reviewing all those systems we can, however, say that if they are inexpensive, in terms of the measuring system itself ( and not in terms of cost of performing the measurement), they usually have poor performances. If on the other hand, they have good performances they are always expensive. A relatively inexpensive and reliable system would then be interesting particularly for automatic weather stations in remote areas. This reason prompted our feasibility study of a sonar system.

Beside its automaticity and the possibility of direct telemetric transmission, the other prerequisite for the system was a low power consumption. Using the system in pulsed mode, but at a rate fast enough to measure snow thickness variation, the power used would be less than 1/30 watt. Finally, as with all automatic meteorological instruments one of the main problems is to keep the sensor clean and unobstructed particularly under icing conditions. Although, we never had severe icing conditions during the past winter when the prototype was field tested, we never had any problem and feel that there should be none since the sonar uses ultra sonic waves and therefore is self-cleaning.

In what follows, we will then describe the principle of the measurement and its parameters, outline the design on the prototypes that were built, indicate the first experimental results obtained and finally make some comments on these results in order to pave the way for a further development of this system.

### PRINCIPLE OF MEASUREMENT

The principle of measurement is shown in Fig. 1. The ultrasonic transmitter T sends a short ultrasonic pulse train that travels downward towards the snow surface. The ultrasonic wave is reflected towards the ultrasonic receiver R. This permits one to measure

---

\*Alain Caillet is now with Atmospheric Environment Service, Downsview, Ontario.

Proceedings of the Eastern Snow Conference, 36th Annual Meeting, Alexandria Bay, N.Y., June 7-8, 1979.

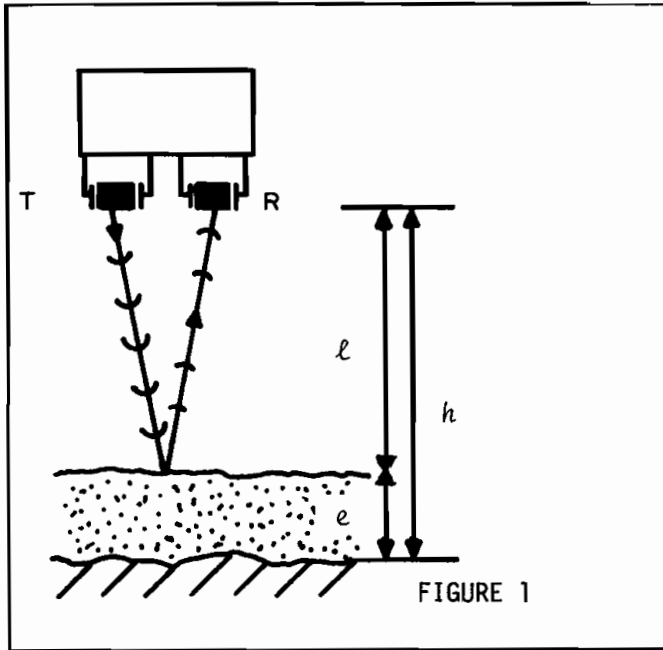

Figure 1.

Principle of Snow- Thickness Measurement System by Sonar Ranging.

the time interval  $t$  between the emission of the pulse train and its reception after reflection. This time interval  $t$  will be given by:

$$t \approx 2l/v \quad (1)$$

where  $l$  is the distance between the snow layer and the transmitter-receiver system and  $v$  the speed of sound in air. If the distance  $h$  between the transmitter-receiver system and ground is known the thickness of the snow layer  $e$  is given by:

$$e = h - l = h - vt/2 \quad (2)$$

so that as in radar the distance is obtained from a time measurement.

The reasons for choosing ultrasonic waves instead of sonic waves are manifold. First, the dimension of the transmitter and receiver; they will be of the order of the wavelength of the wave so much smaller in the ultrasonic than in the sonic region. Furthermore, there will be less sensitive to man made or animal made or other natural (wind, thunder) interferences. (Luckily, bats do not fly when there is snow!) Also, the accuracy of distance measurement is somewhat related to the wavelength of the pulse train used and will be a priori higher at higher frequency. Finally there is the transducer self-cleaning properties that we recalled earlier.

#### PARAMETERS OF THE MEASUREMENTS

Various parameters must be taken into account; they are related to the geometry of the system, the acoustic properties of the snow layer and the meteorological conditions of the environment.

First, as can be seen in Fig. 1, the distance between the transmitter and receiver should be taken into account and equation (1) should be corrected by a trigonometric factor. However, Fig. 1 is not to scale, the distance T - R is much smaller than  $l$  and the required correction is much smaller than the other errors involved and therefore unnecessary.

Next, as in all echo ranging systems there is a minimum distance the system can measure. This distance is related to the diameter of the antenna and the wavelength; it ensures that one is outside of the Fraunhofer diffraction region. In the prototype

built, the distance was of the order of 10 cm and for all practical purposes the system should be installed 20 cm higher than the highest snow level ever expected.

The snow characteristics determining the amplitude and shape of the echo ( and thus its detectability) are the acoustic properties of the snow layer. Let us recall that the ratio of the acoustic energy received at the receiver ER to the acoustic energy transmitted by the transmitter ET is given by

$$ER/ET = \left( \frac{Ra - Rs}{Ra + Rs} \right)^2 e^{-\mu \ell} \quad (3)$$

where Ra and Rs are respectively the acoustic impedance of the air and of the snow while the exponential term takes into account the standard absorption as a function of the distance travelled by the sound.

The acoustic impedance of the snow surface will vary greatly from that of a well reflecting surface, when there is a crust at the surface like after a freezing rain, to that of a very poor reflector after the fall of a light snow (ISHIDA, 1965). In the later case, because of the porosity of the snow, and its irregular surface, one goes progressively from the impedance of the air to that of packed snow and this change of impedance greatly reduces the reflectivity. Finally, one must remember that acoustic impedances like their electric counterparts are usually complex numbers, so that phase shifts will be introduced in the reflected waves. Consequently, not only the amplitude but the shape of the reflected wave will vary with the acoustic impedance of the snow.

The main meteorological parameter affecting sonar measurements is the air temperature. It can be shown from classical thermodynamics, by considering and assuming air as a perfect gas, that the speed of sound in air  $v$  is given by:

$$v = \alpha \sqrt{\Theta}, \quad (4)$$

where  $\Theta$  is the absolute temperature in K and  $\alpha$  is given by

$$\alpha = \left( \frac{Cp R}{Cv} \right)^{\frac{1}{2}} \quad (5)$$

R is the specific gas constant ( $287.05 \text{ Jkg}^{-1}\text{K}$ ) and Cp and Cv are the specific heat at constant pressure and volume respectively.

If one assumes that air is a diatomic gas then  $\alpha \approx 20.06 \text{ ms}^{-1}\text{K}^{-\frac{1}{2}}$ . So that the speed of air under standard conditions is:

$$v \approx 342 \text{ ms}^{-1}$$

From what has just been said, SONAR ranging will have to include a temperature compensation device. Actually, this property of air is used to measure accurately the temperature of air by measuring the time taken by a sound wave to travel a fixed distance.

The other meteorological parameters will only introduce second or third order effects. Humidity and pressure would alter very slightly the value of  $\alpha$  in (4), (Harris, 1966); vertical wind will always be too small to be taken into account within the accuracy of the system. As for horizontal wind, although its speed could be as high as 1/10 the speed of sound, it can also be neglected in first approximation since it is perpendicular to the wave propagation.

Finally, let us mention the possibility of echos due to snowflakes or rain drops during precipitation ; however, no such effects were observed during the experiments.

### SYSTEM DESCRIPTION

Two sonar prototypes were built to test the feasibility of the system: a laboratory prototype to make reflectivity measurements on snow stored in a large freezer, and a field prototype to record the snow level under actual field conditions. The laboratory system had a digital output and display, the field prototype used analog circuits throughout.

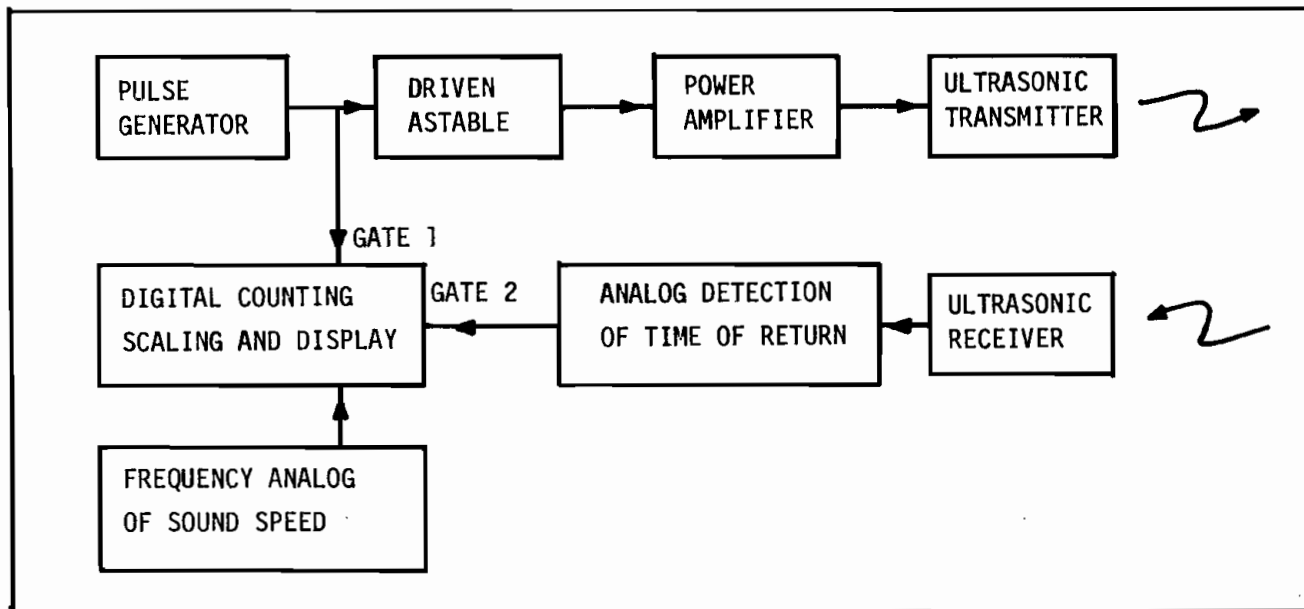

Figure 2: Block Diagram of Laboratory Prototype

The block diagram of the electronic circuits of the prototypes are shown in Figs. 2 and 3. Both systems used the same type of electronic transducers. Due to availability and delivery problems, we could not rely on transducers specially built for outside use. Thus transducers from an intrusion alarm system had to be utilized.

The transducers were at the center of a hemispherical reflecting antenna 3 inches in diameter, and mounted with a Helmholtz resonator to increase the antenna gain both at emission and reception (see Fig. 4).

The transmitter circuits were quite similar for both prototypes. First, the pulse generator produced a positive pulse of about 400  $\mu$ s duration (Fig. 5a) at a repetition rate slow enough so that the time between pulses would be longer than the maximum travel time expected, i.e. with no snow on the ground.

This pulse would then enable the driven astable to oscillate for the duration of the pulse at the transducer frequency as shown in Fig. 5b. It would also close a gate in the counting circuit (laboratory prototype) or reset a Flip-Flop (field prototype) to start the time interval measurement (Fig. 5e).

The driven astable and pulse generator can be seen as a burst generator; the number of pulses in the burst, N, could be varied by changing the width of the pulse generator. The height of the echo signal would increase with N up to about N = 10 with the transducers used, and would then remain constant. This is due to the fact that ultrasonic transducers are tuned systems, and the required number of pulses for maximum return is related to the bandwidth of this tuned system and more exactly their Q factor.

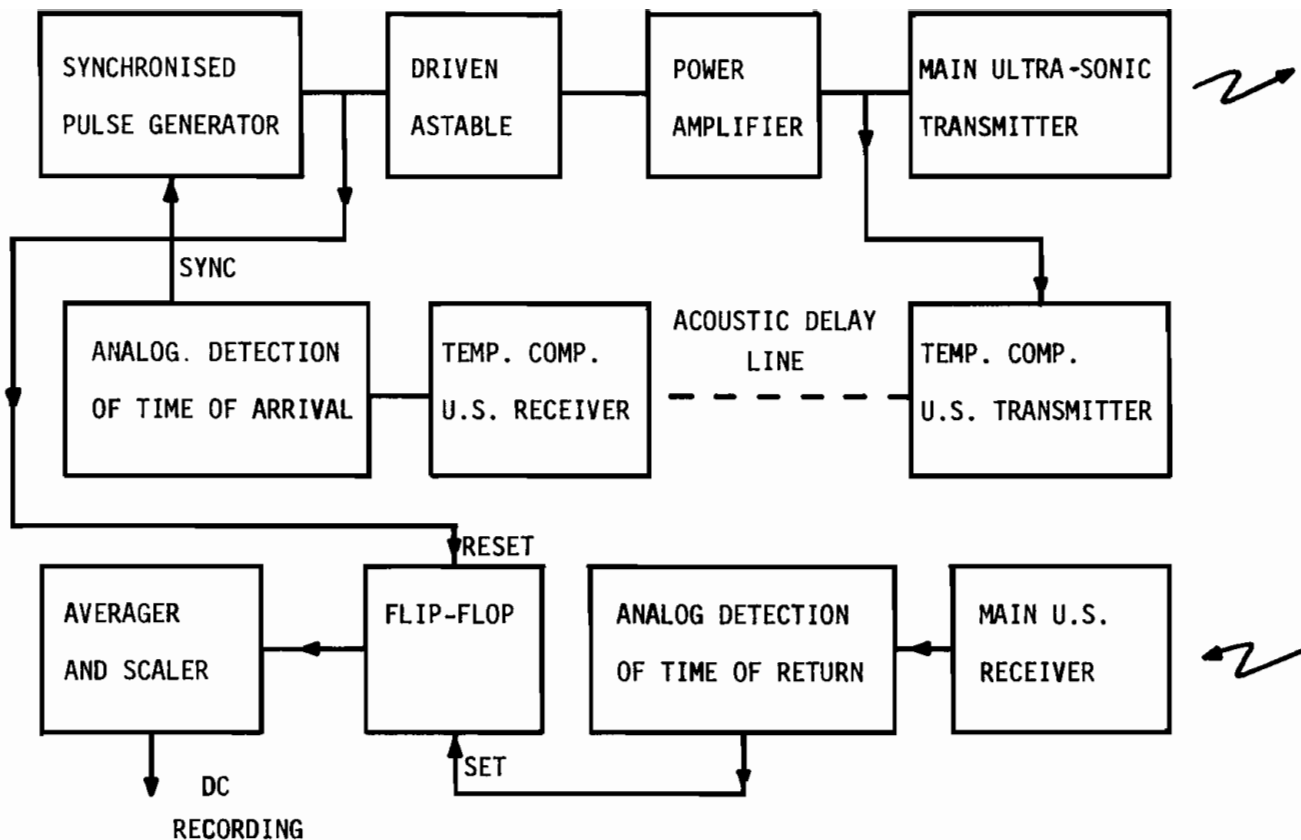

Figure 3: Block Diagram of Field Prototype

The burst generator is then followed by a power amplifier which itself drives the ultrasonic transducer used as the transmitter.

The ultrasonic sound wave so produced travels down to the snow, is reflected back and then travels to the ultrasonic receiver which is basically an ultrasonic transducer identical to that of the transmitter.

The signal at the output of the transducer (Fig. 5c) was preamplified by 60 dB, with the amplifier physically as close as possible to the transducer in order to reduce noise problems. The signal at the output of the transducer being of the order of a microvolt under conditions of low snow reflectivity, special care had to be taken to discriminate it against the noise: band passing, supply filtering and decoupling, care of layout.

The analog detection circuits of the time of return were however quite different for both prototypes. This is mainly due to the fact that the laboratory prototype could always be adjusted locally for optimum performance under various conditions while the field prototype had to perform without adjustment under all conditions.

In the laboratory prototype the preamplifier was followed by an amplifier with adjustable gain, then a full wave rectifier followed by an A.M. detector and finally a comparator with adjustable comparison level. The tripping of the comparator, (Fig. 5d), due to the amplitude of the return echo reaching the comparator level, would then start the counting circuit and display the past measured count. By proper choice of the clock frequency the display could thus be made to indicate directly the snow level in centimeters or inches. Furthermore ten measurements were actually made and averaged before

displaying the result, in order to have the equivalent of a low pass filter for S/N ratio improvement.

In the field prototype, the preamplifier was followed by a band-pass filter realized with a tuned LC circuit which added some further gain. This was then followed by an AGC circuit with JFET control and then again by a demodulator and comparator. The comparator tripping (Fig. 5d) would reset the Flip-Flop (Fig. 5e) and a new measurement cycle would start again with the next pulse of the pulse generator.

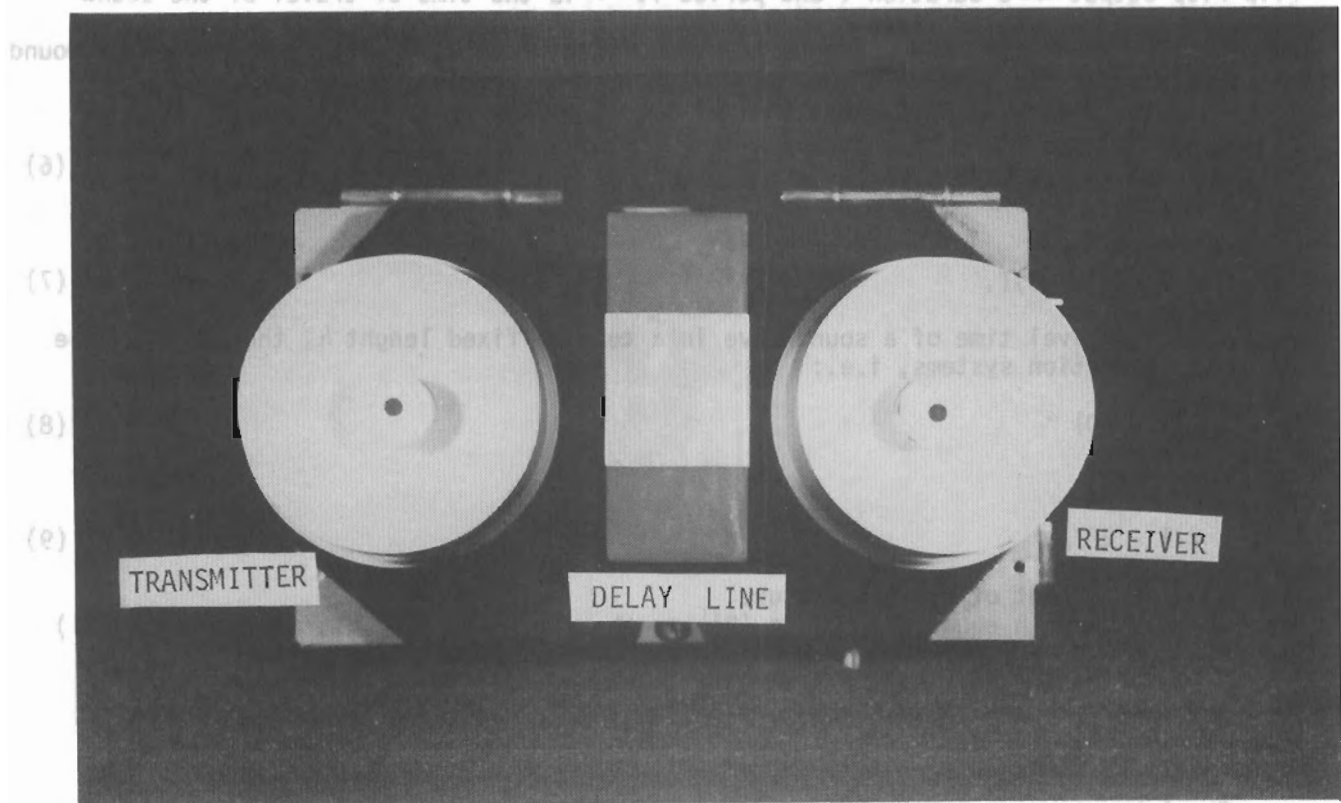

Figure 4: Field prototype, showing the ultrasonic transmitter and receiver in their hemispherical antennas, the delay line in the box between the antennae and the box containing the electronic circuits.

The output of the Flip-Flop was then fed to a low-pass filter with a 0.1 hz cut-off frequency. The repetition rate of the pulse generator being of the order of 100hz, the cut-off frequency was low enough to reject the carrier by 80db (second order low-pass filter) and high enough to follow quite easily any snow level variations. The output of the filter was then fed to a graph recorder situated inside a building. The transducer and the whole electronic circuit were set up outside, fixed to the extremity of an horizontal beam, above the snow. The power supply was also installed in the building so that only low voltage carrying wires were going outside. This was done for security reasons since the test site was not a completely isolated area.

There was also another important difference between the laboratory and field prototypes since one had to be compensated for air temperature variations. This was done using what we think was a very neat way, i.e. using the speed-of-sound-versus-air-

temperature variation itself. The pulse generator would fire at the same time the main ultrasonic transducer and another transducer fixed at the extremity of a tube whose length was equal to twice the distance between the detector and ground. The sound would then travel through this tube at the same speed as the sound wave outside in the air since both were at the same temperature. When the sound wave in the tube would reach an other ultrasonic transducer fixed at the other extremity of the tube, it would be detected (using circuits similar but simpler than the previously described detectors). The detector would then trigger the pulse generator (Fig. 3 and 5f) so that its pulse rate would then vary with the temperature of the air in the tube, that is with the outside air temperature.

To see how the compensation works, let us assume that (Fig. 5e) the signal at the Flip-Flop output has a duration  $\tau$  and period  $T$ .  $\tau$  is the time of travel of the sound wave from the transmitter to the snow level and back to the receiver, so that  $\tau = 2\ell/v(\theta)$ , where  $\ell$  is the distance transducer-snow level and  $v(\theta)$  is the speed of sound which depends on the temperature  $\theta$ . The signal at the output of the low pass filter will be the average value of the signal at the Flip Flop output that is:

$$e \propto 1 - \tau/T \quad (6)$$

or

$$e \propto 1 - 2\ell/v(\theta)T, \quad (7)$$

but  $T$  is the travel time of a sound wave in a tube of fixed length  $h$ , that of the tube in the compensation systems, i.e.:

$$T = h/v(\theta) \quad (8)$$

so that:

$$e \propto 1 - 2\ell/h. \quad (9)$$

which is independant of the temperature.

(The symbols used in equations (6) to (8) are the same as in Fig. 1, and equations (1) and (2) ).

## EXPERIMENTAL RESULTS

The laboratory prototype was used

- to study temperature effects on the electronic circuit, and mainly the frequency shift of the transducers with temperature,
- to study the directionality of the system,
- the resolution of the system and the reflectivity of the snow under particular conditions.

The last point showed that the reflectivity of the snow does not depend so much on the type of snow cover, light snow or hard packed snow, but much more on the regularity or irregularity of the snow surface; with irregularities of the order of magnitude of the wave length the reflectivity could be a hundred times lower than with a very flat regular surface. Such irregularities would happen at the beginning and during a snowfall, and also at the snowmelt. This decrease of the amplitude of the return echo could only be due to destructive superposition of the reflected waves from the top and bottom of the irregularities.

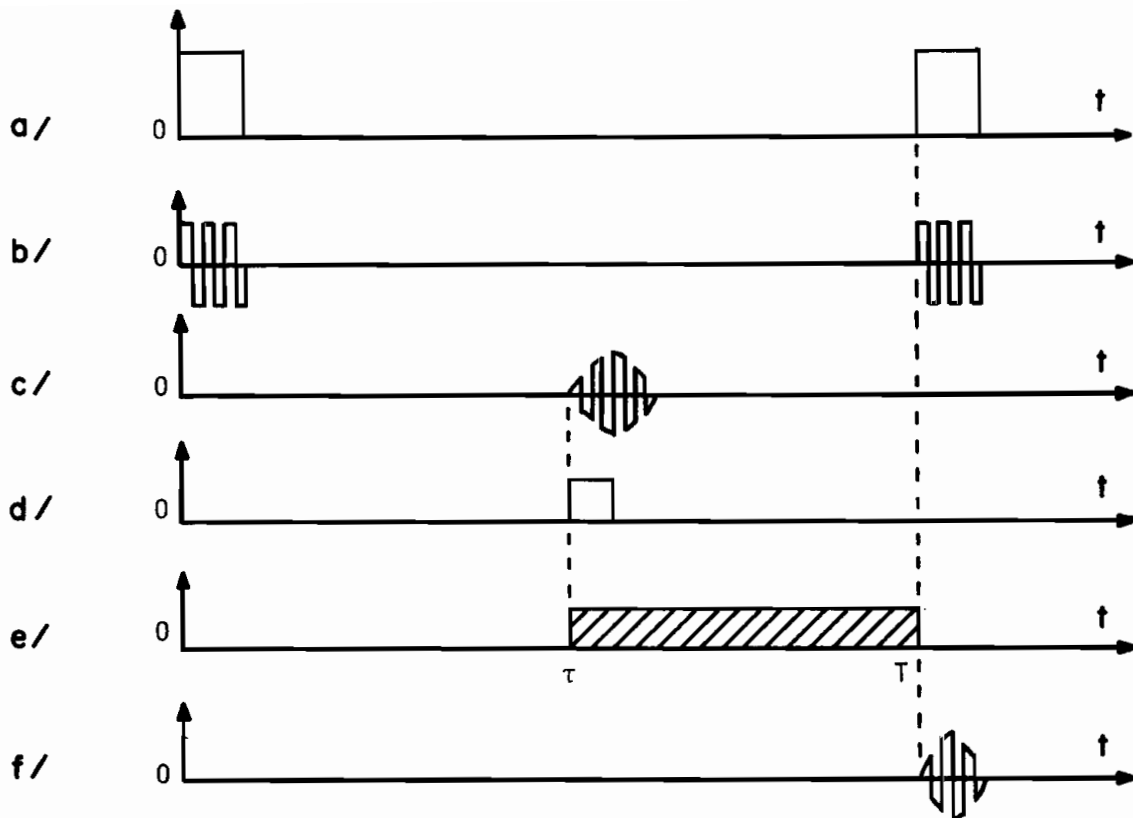

**Figure 5:** Main signals of the Electronic circuits

- 5a: Signal at the output of the pulse generator
- 5b: Signal at the transmitter input
- 5c: Echo at the receiver output
- 5d: Signal at the comparator output, triggered by the echo
- 5e: Signal at the Flip-Flop output, reset by signal a, set by signal d
- 5f: Echo from the compensation system, synchronizes the pulse generator

The construction of the field prototype was finished at the end of February and was set up outside from this date until the beginning of April. Unfortunately, there was only one snowfall during this period and a very light one. (Under other circumstances one would say that this was actually very fortunate!) The system was then tested by putting a board covered with a known height of snow below the detector and removing it after a while, while at the same time recording the output signal on a graph recorder. The graph always showed the predicted steps and a smooth trace in between.

We had a system failure however when the temperature reached 0°C. This particular problem was due to the fact that we could not use the same type of transducers for the compensation and the measuring circuit because of the delivery problem. Their resonant frequencies were separated by few Khz and this separation increased with increasing temperature. Since both transducers were driven by the same oscillator the echo of the compensation circuit would be much smaller under "hot" than under "cold" condition so that the



synchronized pulse generator could not synchronize any more or would synchronize erratically. The snowmelt could then not be recorded evenly, but only by steps, if the nights were cold enough so that the system would resynchronize.

## CONCLUSION

Although it is clear, from what has been said, that the system and circuit still require further development and even theoretical studies, we think however that we have shown that the proposed system is quite feasible, i.e. that one should be able to design a snow level detector by SONAR ranging, for a low component cost and using low power. We are justified to make the above comment because

- a) although the field prototype did not actually work under all conditions, we however could always observe a return signal showing a recognizable echo (The preamplifier output was returned to the building as a phantom signal on the power lines and was then displayed permanently on an oscilloscope to check for the shape and amplitude of the echo).
- b) although we could neither use special transducers, neither special electronic components for outside use (military type) but only standard types, the system still worked under very cold conditions (-20°C) and at times, rainy conditions. From a designer point of view, this is a plus for a system and indicated that by using proper components (which were not available to us in due time) the system should be reliable.

We must however again emphasize that more development and circuit redesign will have to be carried on before getting fully working and commercial instruments. One must also remember that such a system will only deliver the snow level, not the water content of the snow layer. To measure this parameter with a SONAR system would not only require positioning the system at ground level, directed upwards, but would also necessitate the use of different concepts and circuits.

Finally, since ultrasonic systems can be used and are used to measure temperature and wind speed and direction and since, theoretically at least (Harris, 1966), they could also be used to measure humidity, (humidity changes the parameter  $\mu$  in (3) ), it appears that ultrasonic systems should have a future in automatic weather stations. The only missing parameter is pressure but this might be the easiest part to solve since pressure transducers and subsystems are already available.

## REFERENCES

- HARRIS, C.M., 1966: ABSORPTION OF SOUND IN AIR VERSUS HUMIDITY AND TEMPERATURE. J. of Acous. Soc. America. 40, 148-159.
- ISHIDA, T., 1965: ACOUSTIC PROPERTIES OF SNOW. Contrib. from Inst. of low. temp. Sciences, Ser. A, No. 20, 23-63.